

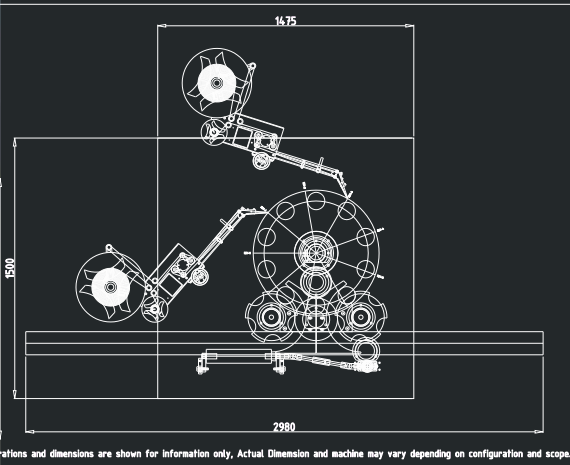

BROTHERS
PHARMAMACH (INDIA) PVT. LTD.

LABELSTIK 120R.Twin

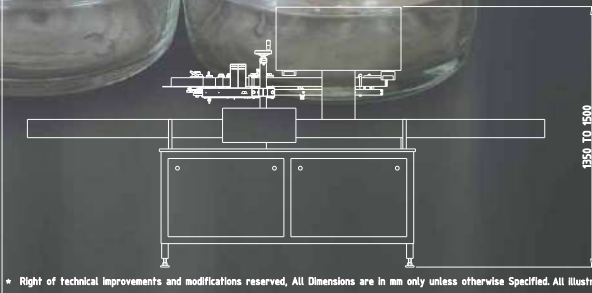

* Right of technical improvements and modifications reserved, All Dimensions are in mm only unless otherwise Specified. All illustrations and dimensions are shown for information only, Actual Dimension and machine may vary depending on configuration and scope.

Automatic Twin Head Rotary Wrap Round Sticker Labelling Machine

Automatic Vertical Rotary Sticker Labelling Machine Model LABELSTIK-120R.Twin is suitable to apply Front & Back, Body & Neck Label on Rectangular, Square, Round Shape Bottles. Machine having Twin Label Dispenser to apply Two Label on One Product and suitable for applying Wrap Round or Partial Label on Rectangular, Square or Round Shape bottles. Machine suitable for covering total body of bottles having special shape where the Linear Labelling Machine is not suitable to apply Labels. The Machine incorporates latest sophisticated PLC Control SERVO Label Dispensing system with user friendly Sensing system for Label and Product. It is capable of Labelling up to 100 units per minute depending on products and label size.

Machine is fully synchronized with all operations including Product Conveyor, Feed Worm, Infeed-Exit Star Wheel and Label Dispensing for optimum Labelling accuracy, it also helps to change the Labelling speed online for ease of operator.

LABELSTIK-120R.Twin, with unique single point synchronized speed control system. The Inbuilt Automated Label Length detection systems eliminates any need for manually feeding and storing of Label Length data in memory and retrieving the same every time for change of Label Size & re-starting the machine. The System thus saves valuable time, avoiding machine-down time, and helps achieve higher production.

Machine can be supplied with Optional Toughened (Tampered) Glass Safety Cabinet. Machines having required all basic features as a standard fitment to match the current market needs and also saves cost and time. Machine different Version also available with Single, Double or Triple Dispenser to Apply Single, Twin or Triple Label on Single Product.

OPTIONAL FEATURES :

- Label Roll Empty - Machine Stop System with Alarm
- Missing Label in Roll - Machine Stop System with Alarm
- Special Label Sensor for sensing Transparent Film Labels which does not have any sensing mark on it.
- Option of Contact Coder, Hot Foil Coder, HP Cartridge Coder and Inkjet Coder with various speed range available.
- Toughened Glass Safety Cabinet for Machine
- Tower Light showing the machine status / operation
- Special Sensing system for checking missing label on product
- Low Compressed Air - Machine Stop with Alarm system for pneumatically operated coding system
- Vision System for checking Barcode, presence or absence of Coding or Pharma code on labels
- Online pneumatically operated product rejection system
- 21CFR Part 11 Compliance

For Built-in / Optional* Items Refer UNIQUE FEATURES Page for more details.

Email : sales@brothers.in
Export : sales1@brothers.in

TECHNICAL SPECIFICATIONS

- Label Height : 8 mm to 90 mm Standard*
- Label Length : 12 mm Minimum
- Label Roll Dia. : 400 mm
- Core Dia. : 75/76 mm
- Gap Between two Labels : appx. 3 mm
- Product Size : As per customers requirement
- Electrical : 220 VAC Single Phase Power Supply (50/60 Hz)
- Power : 2.0 Hp
- Speed : 40-100 Labels per minute depending on Product and Label Size.
- High Speed 240 Products per minute also available on request.
- Conveyor height : 830-875 mm*
- Overall dimension : 2980 mm(L) X 1500 mm(W) X 1500 mm (H)

* Specification can be changed as per customers requirements

Phone : +91 79 40213213 / 25831346

www.brothersindia.com